

Fig. M650 Ductile Iron - Swing Pattern



FEATURES & BENEFITS

- Suitable for velocities of up to 3 metres/second
- Ideal for water or other liquids
- Bolted cover
- Suitable for mounting in horizontal and vertical pipelines



MATERIAL SPECIFICATION

Component	Material	Specification BS EN
Cover	Ductile Iron	1563 EN-JS 1050
Cover Gasket	Asbestos Free	-
Hinge Pin	Stainless Steel	970 420537
Hinge	Ductile Iron	1563 EN-JS 1050
Disc	Ductile Iron	1563 EN-JS 1050
Disc Face Ring	Bronze	1982 CC491K
Body Ring	Bronze	1982 CC491K
Body	Ductile Iron	1563 EN-JS 1050

DIMENSIONAL DRAWING

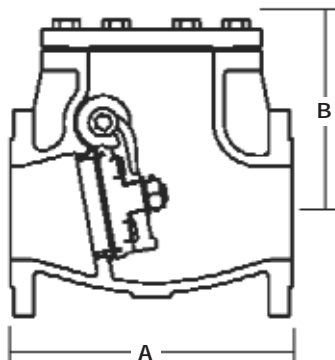

DIMENSIONS & WEIGHTS

Nom Size	mm	50	65	80	100	125	150	200	250	300
A	mm	203	216	241	292	330	356	495	622	699
B	mm	121	135	141	168	182	215	267	305	343
Weight	kg	16	22	28	40	62	82	144	232	310

PRESSURE/ TEMPERATURE RATING

BS EN 12334 PN25
25 bar from -10 to 120°C
21.5 bar at 220°C

TEST PRESSURES (HYDRAULIC)

PN25
Shell: 37.5 bar
Seat: 27.5 bar

SPECIFICATION

BS EN 12334:2001 PN25.
Horizontal swing pattern.
Bolted cover.
Flanged to BS EN 1092-2 PN25.
Copper alloy trim.
Suitable for mounting in horizontal and vertical pipelines (with vertical flow upwards).

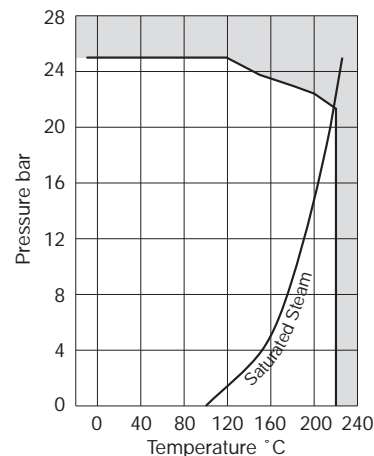

Every effort has been made to ensure that the information contained in this publication is accurate at the time of publishing. Hattersley Ltd assumes no responsibility or liability for typographical errors or omissions or for any misinterpretation of the information within the publication and reserves the right to change without notice.